

A B C D E F G H

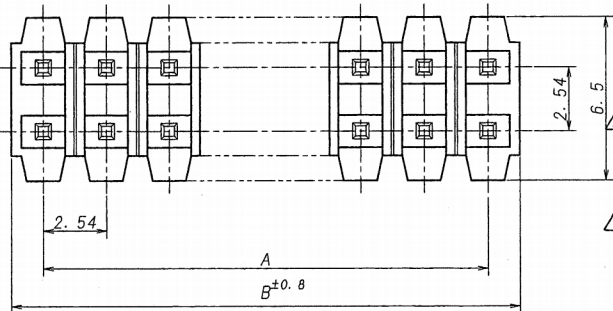

極数	部品番号	A	B	NOTE	極数	部品番号	A	B	NOTE
CKT	PARTS NO.				CKT	PARTS NO.			
4	9204B-2-04Z128-PT1	2.54	5.08		40	9204B-2-40Z128-PT1	48.26	50.80	
6	-06	5.08	7.62		42	-42	50.80	53.34	
8	-08	7.62	10.16		44	-44	53.34	55.88	
10	-10	10.16	12.70		46	-46	55.88	58.42	
12	-12	12.70	15.24		48	-48	58.42	60.96	
14	-14	15.24	17.78		50	-50	60.96	63.50	
16	-16	17.78	20.32		52	-52	63.50	66.04	
18	-18	20.32	22.86		54	-54	66.04	68.58	
20	-20	22.86	25.40		56	-56	68.58	71.12	
22	-22	25.40	27.94		58	-58	71.12	73.66	
24	-24	27.94	30.48		60	-60	73.66	76.20	
26	-26	30.48	33.02		62	-62	76.20	78.74	
28	-28	33.02	35.56		64	-64	78.74	81.28	
30	-30	35.56	38.10		66	-66	81.28	83.82	
32	-32	38.10	40.64		68	-68	83.82	86.36	
34	-34	40.64	43.18		70	-70	86.36	88.90	
36	-36	43.18	45.72		72	9204B-2-72Z128-PT1	88.90	91.44	
38	9204B-2-38Z128-PT1	45.72	48.26						

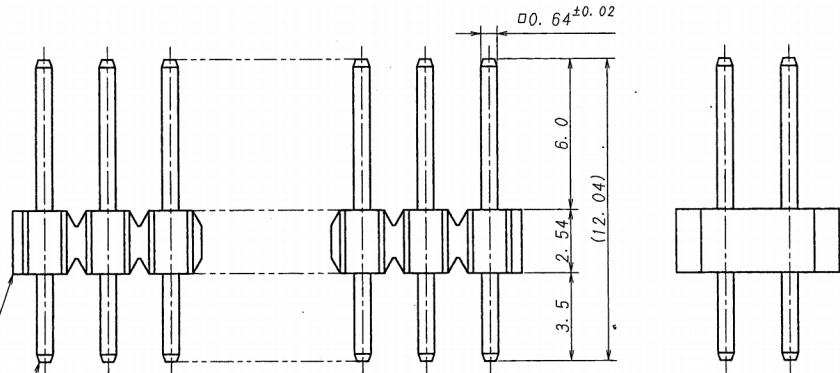

仕様

- 最大定格電圧電流 : 250V, 3A (AC, DC)
- 使用温度範囲 : -40~+105℃
- 本製品はウイスキーの発生を通常品よりも抑制する効果を持たせた製品ですが、ウイスキーの発生を無くすことを保証する製品ではありません。

NOTE

- MAXIMUM RATING VOLTAGE AND CURRENT : 250V, 3A (AC, DC)
- TEMPERATURE RANGE : -40~+105℃
- THIS PRODUCT HAS EFFECT TO SUPPRESS THE OCCURRENCE OF WHISKER THAN NORMAL. HOWEVER, IT IS NOT A PRODUCT THAT GUARANTEES THAT THERE IS NO OCCURRENCE OF WHISKER.

ISSUED  
15.3.-9

△					MATERIAL 材質	SCALE 尺度	UNIT 単位	TITLE 名称
△					① ベース : ガラス入り46ナイロン樹脂 黒色, UL94V-0 ① BASE : GLASS FILLED 46NYLON UL94V-0 COLOR: BLACK	DR 15-3-3 Y. Kojima	DSN '88-2-15 Fukuda	9204シリーズ ピンヘッダー SERIES 9204 PIN HEADER
△	49405	NOTE REV	Y.K	5/16	② 端子/PIN : 黄銅/BRASS	ANGLE 角度 ±		EDP No
△	26890	REVISED	S.K	M.T	FINISH 仕上げ	3RD ANG. PROJ. 三角法	CHK 1/15 Jima	APP 1/13 M. Yabuki
△	24062	REVISED	M.K	F.N	前めっき/PRE-PLATE (ニッケル下地めっき/OVER NICKEL PLATE 1μmMIN. スズリフローめっき/TIN REFLOW PLATE 2μmMIN.)			PARTS No 部番 △ IMSA-9204B-2-**Z128-PT1
△	21206	REVISED	H.K	J.O				DWG No 図番 △ 110-409204-018
△	19751	RELEASED	K.H	J.O				REV 4
LTR 記号	ECN NO	REVISION RECORD 記	DR	CHK	DATE 年月日			

DO NOT SCALE DRAWING.

REDUCED COPY