

A B C D E F G H

PRODUCT WITHDRAWAL DIRECTION
製品引き出し方向

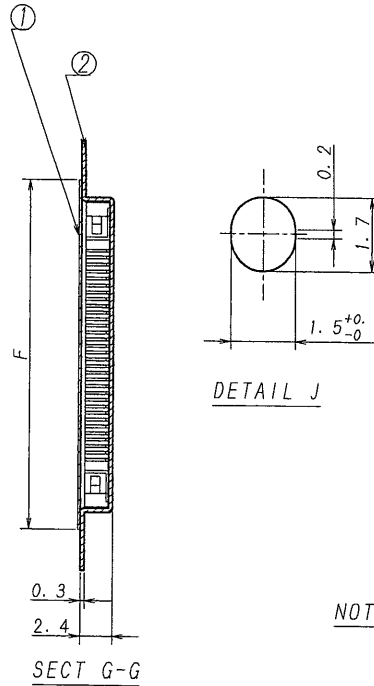
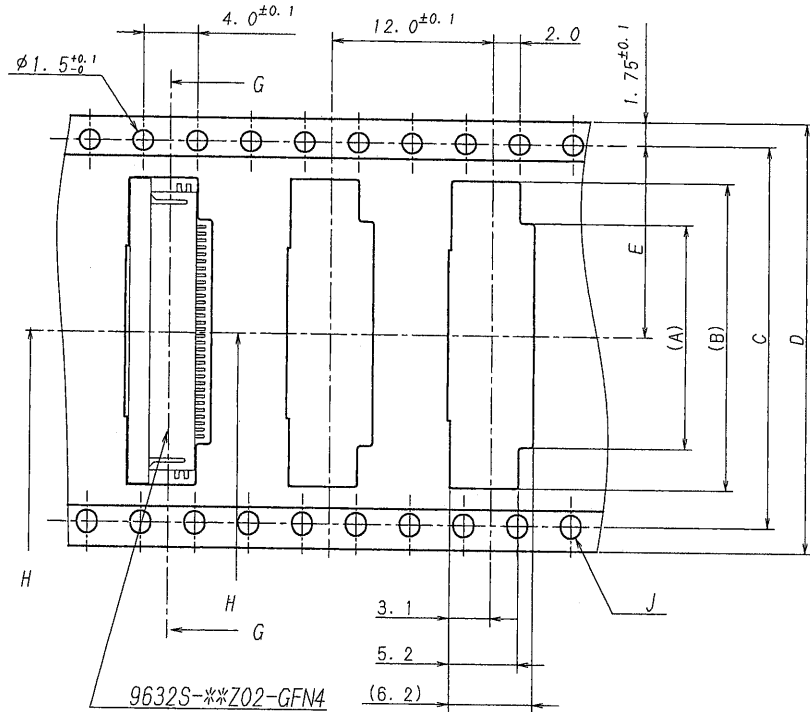

板数/CKT	製品番号/PARTS No	A	B	C	D	E	F
21	9632S-21Y801	11.1	17.3		24	11.5	21.5
22	-22	11.6	17.8				
23	-23	12.1	18.3				
24	-24	12.6	18.8				
25	-25	13.1	19.3				
26	-26	13.6	19.8				
27	-27	14.1	20.3	28.4	32	14.2	26.0
28	-28	14.6	20.8				
29	-29	15.1	21.3				
30	-30	15.6	21.8				
31	-31	16.1	22.3				
32	-32	16.6	22.8				
33	-33	17.1	23.3				
34	-34	17.6	23.8				
35	-35	18.1	24.3				
36	-36	18.6	24.8				
37	-37	19.1	25.3				
38	-38	19.6	25.8				
39	-39	20.1	26.3				
40	-40	20.6	26.8				
41	-41	21.1	27.3	40.4	44	20.2	37.0
42	-42	21.6	27.8				
43	-43	22.1	28.3				
44	-44	22.6	28.8				
45	-45	23.1	29.3				
46	-46	23.6	29.8				
47	-47	24.1	30.3				
48	-48	24.6	30.8				
49	-49	25.1	31.3				
50	9632S-50Y801	25.6	31.8				

NOTE 1. 梱包数量/UNIT QUANTITY: 3000
2. リードテープ長さ/LEAD TAPE LENGTH

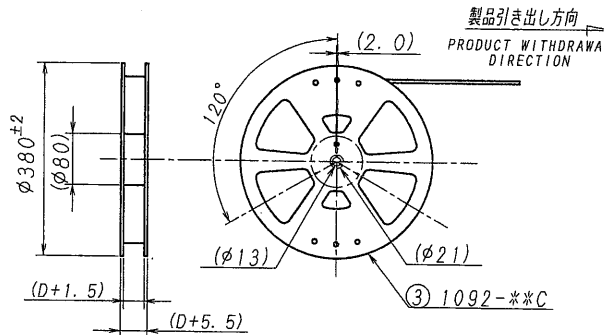
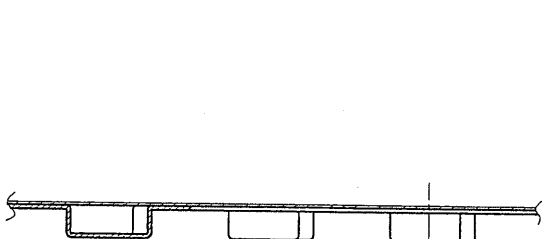
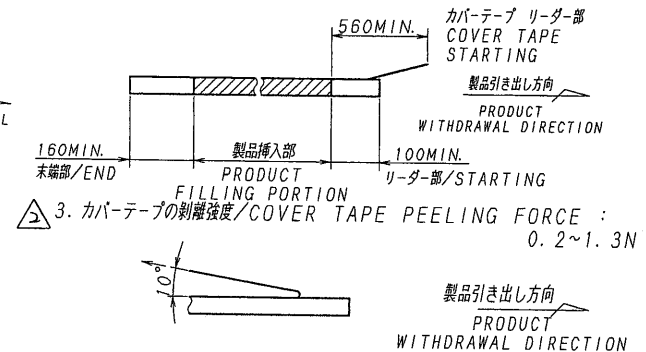

ISSUED
13.9.-6
IRISO
ENG. DEPT.

MATERIAL 材質				GENERAL TOLERANCES 一般公差		SCALE 尺度		UNIT 単位		TITLE 名称	
① カバーテープ/COVER TAPE: PET TYPE ② キャリアテープ/CARRIER TAPE: A-PET ③ リール/REEL: PS (黒/BLACK)				DIM 寸法 ± 0.3 ANGLE 角度 \pm		DR '13-9-5 D. Kim		DSN '12-7-17 J. Doi		9632シリーズ FFC/FPC ソケット エンボス梱包品 SERIES 9632 FFC/FPC SOCKET EMBOSS PRODUCT	
FINISH 仕上げ				3RD. ANG. PROJ. 三角法		CHK ① K. Kobayashi ② M. Takagi		APP ③		EDP No	
44679 NOTE REV D.K. K.K. '13-9-5						IRISO ELECTRONICS CO., LTD. IRISO 電子工業株式会社				PARTS No 部番 IMSA-9632S-**Y801	
44391 NOTE REV D.K. K.K. '13-7-5										DWG No 図番 120-109632-002	
42136 RELEASED T.D. K.Y. '12-7-17										REV. 2	
LTR 記号 ECN NO REVISION RECORD 記号 DR CHK DATE 年月日											

DO NOT SCALE DRAWING.