

| 極数/CKT | 製品番号/PARTS No. | A    | B  | C    | D    | E  | F      | G      | W  |
|--------|----------------|------|----|------|------|----|--------|--------|----|
| 6      | 9856B-06Y950   | 7.2  | 15 | 14.2 | 28.4 | 26 | 80     | 2±0.1  | 32 |
| 8      | 9856B-08Y950   | 9.2  | 17 |      |      |    |        |        |    |
| 10     | 9856B-10Y950   | 11.2 | 19 |      |      |    |        |        |    |
| 12     | 9856B-12Y950   | 13.2 | 21 |      |      |    |        |        |    |
| 14     | 9856B-14Y950   | 15.2 | 23 |      |      |    |        |        |    |
| 16     | 9856B-16Y950   | 17.2 | 25 |      |      |    |        |        |    |
| 18     | 9856B-18Y950   | 19.2 | 27 | 20.2 | 40.4 | 37 | 2±0.15 | 44     |    |
| 20     | 9856B-20Y950   | 21.2 | 29 |      |      |    |        |        |    |
| 22     | 9856B-22Y950   | 23.2 | 31 | 26.2 | 52.4 | 49 | 80     | 2±0.15 | 56 |
| 24     | 9856B-24Y950   | 25.2 | 33 |      |      |    |        |        |    |
| 26     | 9856B-26Y950   | 27.2 | 35 |      |      |    |        |        |    |
| 28     | 9856B-28Y950   | 29.2 | 37 |      |      |    |        |        |    |
| 30     | 9856B-30Y950   | 31.2 | 39 | 34.2 | 68.4 | 65 | 100    |        | 72 |

NOTE

- 1. 梱包数量 / UNIT QUANTITY : 150
- 2. リードテープ長さ / LEAD TAPE LENGTH

製品引き出し方向  
PRODUCT WITHDRAWAL DIRECTION

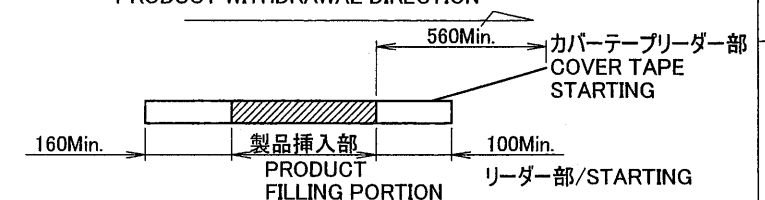

- 3. カバーテープの剥離強度 / COVER TAPE PEELING FORCE : 0.2~1.3N

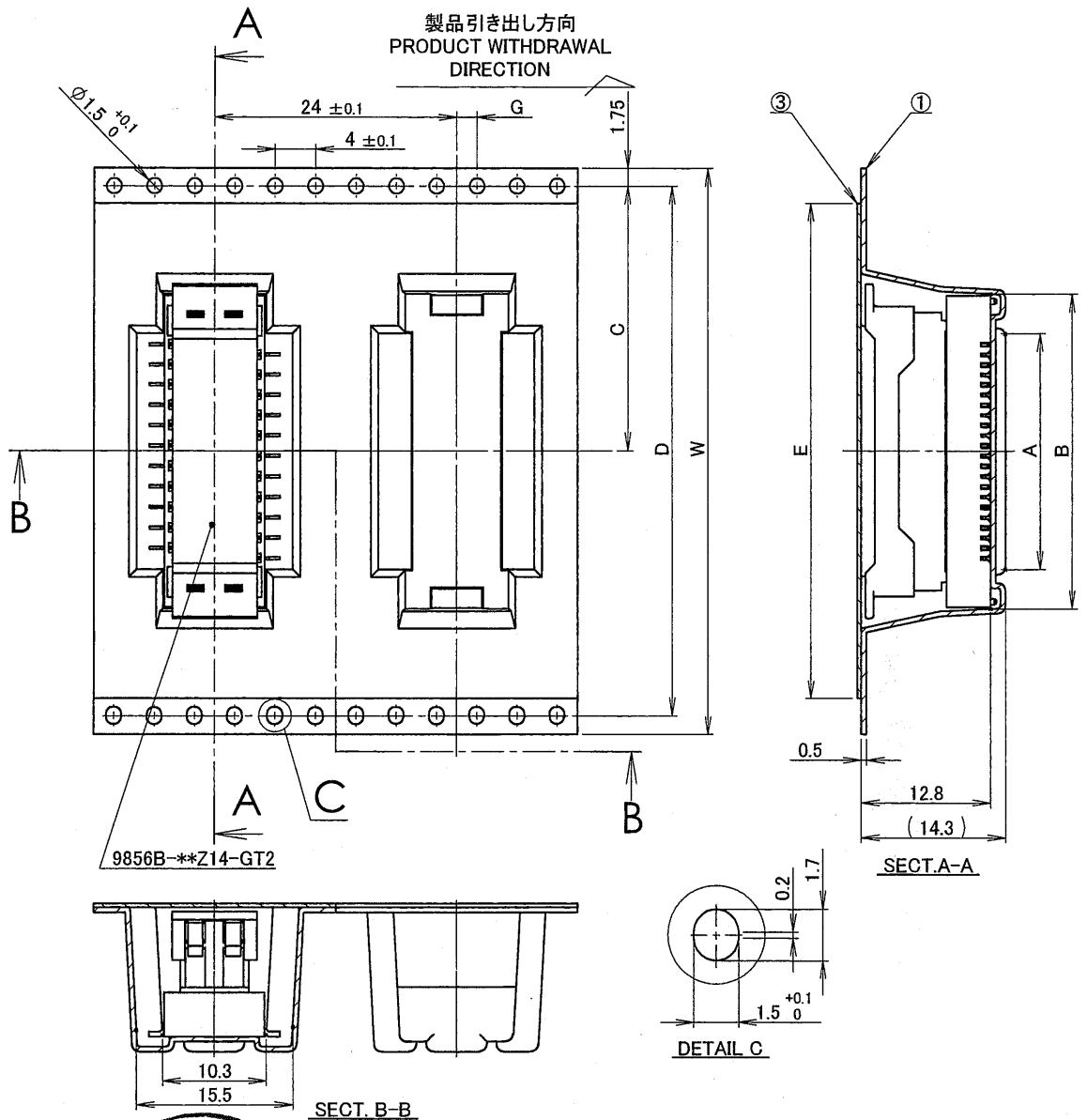
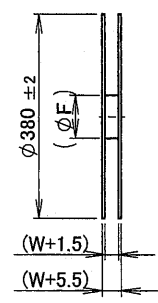
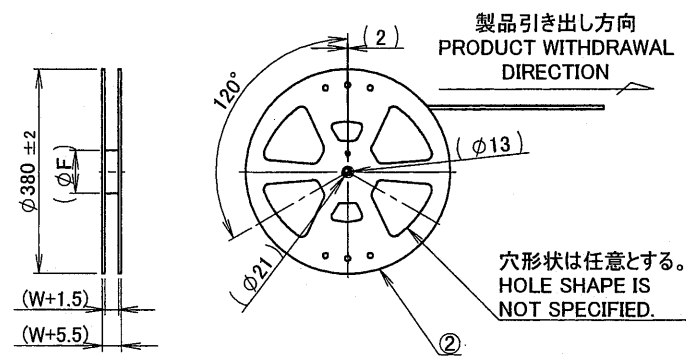
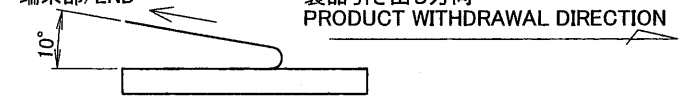

9856B-\*\*Z14-GT2

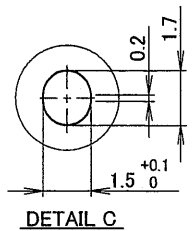
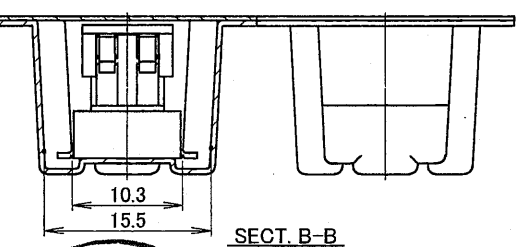

**ISSUED**  
14.7.18

**IRISO**  
ENG. DEPT.

487/73 RELEASED D.K. H.T. 14-06-27

| TR 記号 | BCN No | REVISION 記号 | RECORD 記号 | DR | CHK | DATE 年月日 |
|-------|--------|-------------|-----------|----|-----|----------|
|       |        |             |           |    |     |          |

MATERIAL 材質

- ①キャリアテープ/CARRIER TAPE : PS
- ②リール/REEL : PS(黒/BLACK)
- ③カバーテープ/COVER TAPE : PET TYPE

FINISH 仕上げ

GENERAL TOLERANCES 一般公差

DIM 寸法 ± 0.3

ANGLE 角度 ±

3RD. ANG. PROJ. 三角法

SCALE 尺度 / 単位 mm

DR '14-06-27 DSKN '12-09-20

CHK 2/4 6/27 H. Takagi APP 2/27 M. Juhin

**IRISO ELECTRONICS CO., LTD**  
**イリソ電子工業株式会社**

TITLE 名称

9856シリーズ プラグ エンボス 梱包品  
SERIES 9856 PLUG EMBOSS PRODUCT

EDP No

PARTS No 部番

IMS A-9856B-\*\*Y950

DWG No 図番

120-209856-008

REV. 0