

枚数/CKT	製品番号/PARTS No.	A	B	C	D	E	F	G
30	9860B-30Y927	13.0	16.7	28.4	32	14.2	26.0	80.0
40	9860B-40Y927	17.0	20.7	40.4	44	20.2	37.0	
50	9860B-50Y927	21.0	24.7					
60	9860B-60Y927	25.0	28.7					
70	9860B-70Y927	29.0	32.7	52.4	56	26.2	49.0	
80	9860B-80Y927	33.0	36.7					
90	9860B-90Y927	37.0	40.7	68.4	72	34.2	65.0	100.0
100	9860B-100Y927	41.0	44.7					
110	9860B-110Y927	45.0	48.7					
120	9860B-120Y927	49.0	52.7					

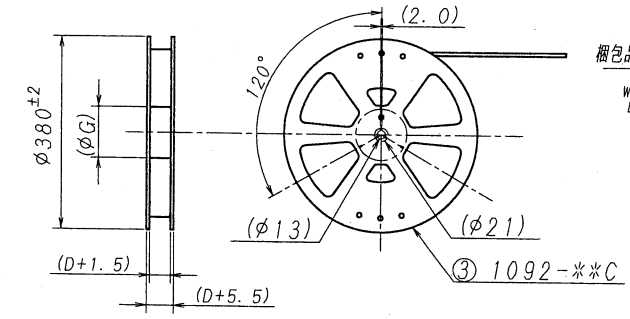
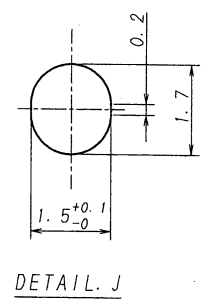
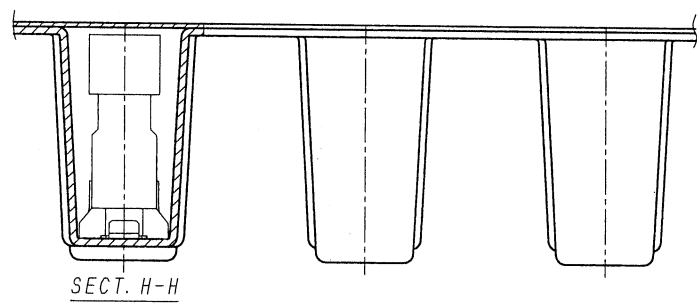
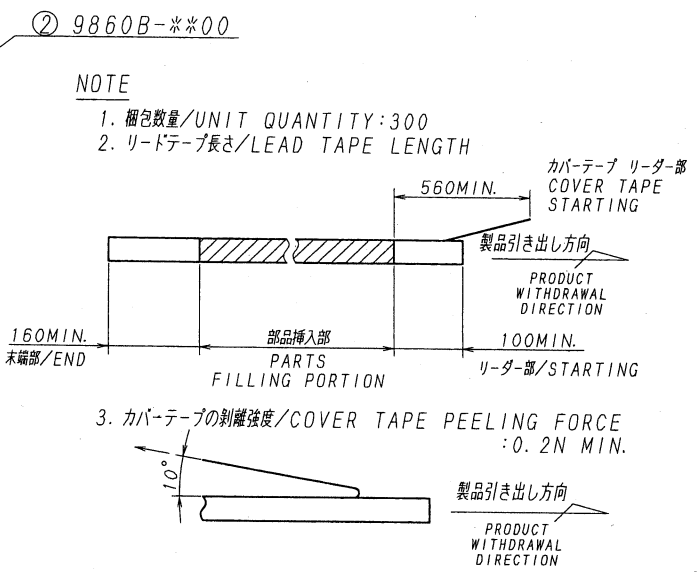
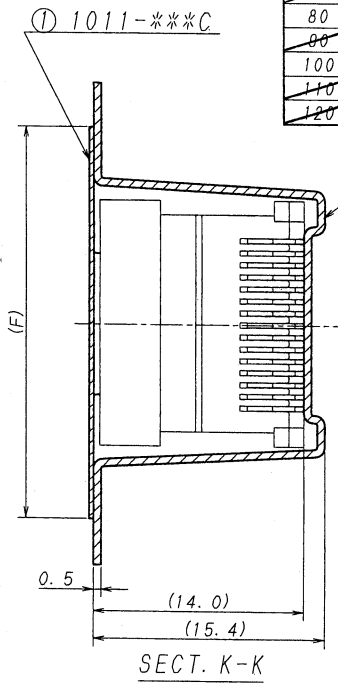
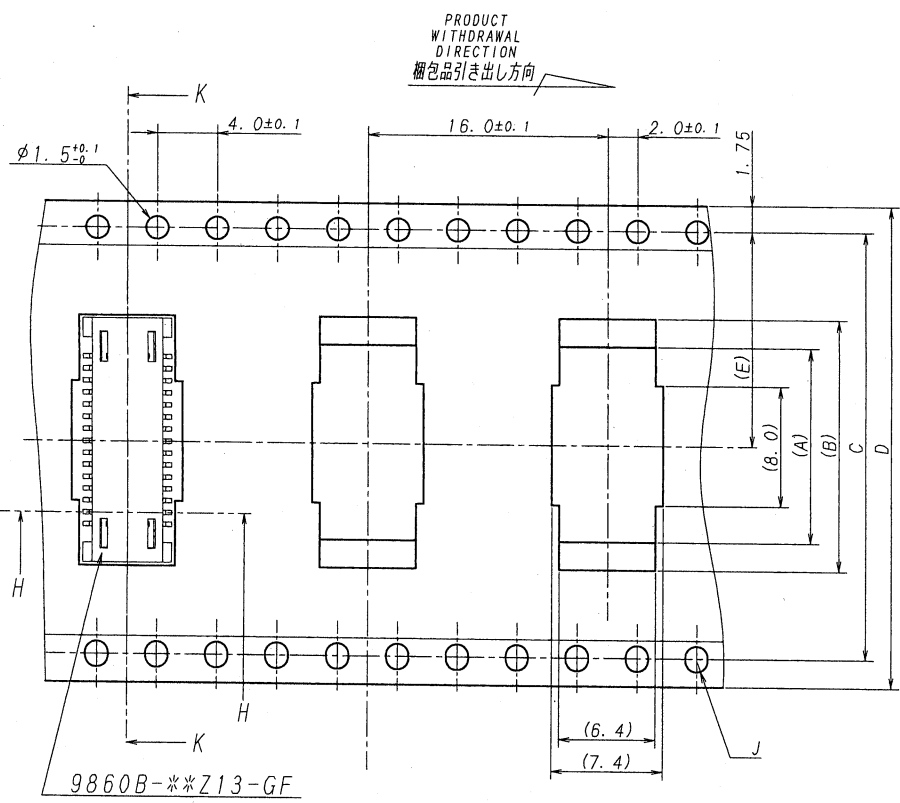

ISSUED  
10.6.29  
IRISO  
ENG. DEPT.

MATERIAL 材質 ① カバートープ/COVER TAPE: PET TYPE ② キャリアテープ/CARRIER TAPE: A-PET ③ リール/REEL: PS (黒/BLACK)					GENERAL TOLERANCES 一般公差 DIM 寸法 ± 0.3 ANGLE 角度 ±		SCALE 尺度 DR 10-6-3 Y. Nakagawa H. Honma APP 10-6-3 C. Matsumoto 5/4 M. JATAWA		UNIT 単位 mm DSN 04-3-13 EDP No PARTS No 部番 9860B-**Y927 DWG No 図番 IMSA-9860B-**Y927		TITLE 名称 9860シリーズ プラグ テーピング 梱包品 SERIES 9860 PLUG TAPING PRODUCT REV. 0	
FINISH 仕上げ					3RD. ANG. PROJ. 三角法		IRISO ELECTRONICS CO., LTD. 伊予電子工業株式会社					
LTR 記号 ECN No 37429 RELEASED 2.11.4.0 10-6-3												

DO NOT SCALE DRAWING.