

製品仕様書/Product Specification

No. IS-9665A 来歴 9
 頁/Page 1/8

標題: 9665 シリーズ 1.0mmピッチ FPC/FFC コネクタ
 SUBJECT: Series 9665 1.0mm Pitch FPC/FFC Connector

制定年月日/ISSUED DATE 2006-02-13
 改訂年月日/REVISED DATE 2013-09-04

1. 適用範囲

本仕様書はイリソ電子工業株式会社製 9665 シリーズ 1.0mmピッチ FPC/FFC コネクタに関する仕様及び性能上の必要事項について規定する。

2. 構造及び寸法

構造、寸法、主要部品の材質、表面処理等は添付図による。

適合 FPC/FFC: 1.0mm ピッチ、厚さ: 0.3±0.05mm

適用ソケット: IMSA-9665S-***-TB/TL/TR/TR-1/
 GFA/GFA-1/GFN4

3. 定格

- (1)最大定格電圧 125V (AC, DC)
- (2)最大定格電流 1.0A
- (3)使用温度範囲 -40~+105℃

4. 試験環境

特に規定のある場合を除き、性能試験は、下記の試験条件のもとで行う。

- 常温 15~35℃
- 常湿 25~85% (相対湿度)

5. 性能

5-1. 電気的性能

| 項目/Item | 条件/Test condition | 規格/Specification |
|--|---|---|
| 1 接触抵抗 Contact Resistance | 短絡電流 1mA、最大開放電圧 20mV、周波数 1kHz のローレベル抵抗計にて測定する。 It shall be measured by the dry electric circuit specified as follows; 1mA, 20mV, 1kHz frequency. | 初期値: 30mΩ以下 各試験後: 50mΩ以下 Initial: 30mΩ or below. After each test: 50mΩ or below |
| 2 耐電圧 Dielectric Withstanding Voltage | 隣接する極間に AC250V を 1分間印加する。 AC 250V shall be applied for one minute to between next terminals. | 絶縁破壊等異常のない事。 Should not have any changes. |
| 3 絶縁抵抗 Insulation resistance | 隣接する極間に DC250V を印加する。 DC 250V shall be applied to between next terminals . | 初期値: 100MΩ以上 耐湿試験後: 100MΩ以上 Initial: 100MΩ or more. After humidity test: 100MΩ or more |
| 4 外観 Appearance | 目視 Visual | 有害となる割れ、剥がれ、ガタ、変形、変色のない事。 Should not have any flaw, scratch, discoloration, and crushed. |

1. Scope

This product specification is applied to IRISO ELECTRONICS CO.,LTD. Series 9665 1.0mm Pitch FPC/FFC Connector.

2. Configuration, dimensions and materials

See the product drawing attached.

FPC/FFC Mated: 1.0mm Pitch, t=0.3±0.05mm

Applied to socket: IMSA-9665S-***-TB/TL/TR/TR-1/
 GFA/GFA-1/GFN4

3. Rating

- (1) Maximum rating voltage: 125 V(AC,DC)
- (2) Maximum rating current: 1.0A
- (3) Temperature range : -40~+105℃

4. Performances

All performance tests, unless otherwise specified, are taken under following environmental conditions.

- Ambient temperature: 15~35℃
- Ambient humidity :25~85%RH

5. Performance

5-1. Electrical performance

5-2. 機械的特性

5-2. Functional Performance

| 項目/Item | 条件/Test condition | 規格/Specification |
|--|---|---|
| 1 端子の保持力 Contact retention force | 端子に 25mm/分の速度で荷重を加え、端子がハウジングより抜け始めるまでの荷重を測定する。 It shall be pulled to the contact at the speed of 25mm per minute, and measured the force when the contact begins to remove from the housing. | 0.98N 以上 0.98N or more |
| 2 挿抜耐久性 Insertion /Extraction endurance | FPC/FFC を 20 回繰返し挿抜を行ない接触抵抗を測定する。 (スライダを開閉し、開閉毎に挿抜する。) The FPC/FFC shall be mated and unmated 20 times and measured The contact resistance. | 50mΩ以下 50mΩ or below. |
| 3 振動試験 Vibration test | FPC/FFC を嵌合した状態にて、振動周波数 10~500~10Hz /掃引時間 12 分、振幅 1.5mm、又は加速度 98m/s ² のいずれか小さい方にて X Y Z 軸方向に各 2 時間計 6 時間の振動を加える。試験中、瞬断の有無の確認、試験後の接触抵抗の測定及び外観観察をする。 The connector and FPC/FFC mated is vibrated in the frequency range of 10~500~10Hz/12min and in the constant vibration amplitude 1.5mm or the acceleration of 98m/s ² . This motion is applied for period of 6 hours in one of 3 multilateral perpendicular directions (X,Y,Z-axis) including mating axis. It shall be tested the discontinuity of the contact current during the test and measured the contact resistance and observed its appearance after the test. | 試験中 1 μs 以上の瞬断の無き事。 50mΩ以下 外観: 異常なきこと Discontinuity: 1 μs or less. 50mΩ or below. Should not have any damages. |

| 項目/Item | 条件/Test condition | 規格/Specification |
|--|---|---|
| 4 衝撃試験 Shock test | FPC/FFC を嵌合した状態にて治具に取り付け、加速度 980m/s ² 、衝撃作用時間 6ms を X,Y,Z,方向の 6 面に各 10 回加え、試験中の瞬断の有無の確認、試験後の接触抵抗の測定及び外観観察する。 The connector and FPC/FFC mated are installed in the machine. They are applied pulses 10 times to each 6 faces of 3 mutually perpendicular directions(X,Y,Z); under conditions as specified ; acceleration of 980m/s ² and shock pulses for a duration of 6ms . It shall be tested the discontinuity of the contact current during the test and measured the contact resistance and observed its appearance after the test. | 試験中 1 μs 以上の瞬断の無き事。 50mΩ以下 外観：異常なきこと Discontinuity : 1 μs or less. 50mΩ or below. Should not have any damages. |
| 5 微加振試験 Contact Pressure | 微加振試験機にて、コネクタを試験基板に取り付け、全極直列に接続する。 The connector shall be set on a P.C.B and all of their terminals are wired in series then tested by test facility. 通電電流 current : 1mA 以下 1mA or below 衝撃値 shock : 980m/s ² 周波数 frequency : 1Hz 衝撃回数 cycling : 20000 回 20000 times 上記条件にて、試験中及び試験後の接触抵抗を測定する。 It shall be measured the contact resistance after the test. | 総合接触抵抗が初期値の 2 倍以下 Twice or less from the initial specified value in total. |
| 6 FPC/FFC 保持力 FPC/FFC retention force | FPC/FFC に 25mm/分の速度で加重を加え、ハウジングより抜け始めたときの荷重を測定する。 The FPC/FFC shall be pulled at the speed of 25mm per minute and measured the force when the FPC/FFC begins to remove from the housing. | 0.29N/極 以上 0.29N/PIN or more. |

5-3. 環境特性

5-3.Environmental performance

| 項目/Item | 条件/Test condition | 規格/Specification |
|--------------------------------|--|---|
| 1 高温保存試験 Heat resistance | FPC/FFC を 5 回挿抜後嵌合した状態にて温度 105±2℃の恒温槽に 1000 時間放置し、放置後接触抵抗測定及び外観観察を行う。 The connector and FPC/FFC mated are unmated at 5 times mated is exposed in the heat chamber 105±2℃ for 1000 hours. It shall be measured the contact resistance and observed its appearance after the test. | 50mΩ以下 外観異常なき事。 50mΩ or below. Should not have any damages. |
| 2 高温高湿保存試験 Humidity | FPC/FFC を 5 回挿抜後嵌合した状態にて温度 60±2℃、相対湿度 90~95%RH の恒温恒湿槽に 1000 時間放置し、放置後接触抵抗測定及び外観観察を行う。 The connector and FPC/FFC mated are unmated at 5 times mated is exposed in the heat chamber 60±2℃, 90~95%RH for 1000 hours. It shall be measured the contact resistance and observed its appearance after the test. | 50mΩ以下 外観異常なき事。 50mΩ or below. Should not have any damages. |
| 3 低温保存試験 Chilly resistance | FPC/FFC を 5 回挿抜後嵌合した状態にて温度 -40±3℃の低温槽に 1000 時間放置し、放置後接触抵抗測定及び外観観察を行う。 The connector and FPC/FFC mated are unmated at 5 times mated is exposed in the chilly chamber -40±3℃ for 1000 hours. It shall be measured the contact resistance and observed its appearance after the test. | 50mΩ以下 外観異常なき事。 50mΩ or below. Should not have any damages. |
| 4 低温負荷試験 Load of chill | FPC/FFC を 5 回挿抜後嵌合状態にて通電電流 1mA、-40±2℃の低温槽中に 96 時間放置する。 The connector and FPC/FFC mated are unmated at 5 times mated is exposed in the chilly chamber -40±2℃, 1mA for 96 hours. It shall be measured the contact resistance after the test. | 総合接触抵抗が初期値の 2 倍以下 外観異常なき事。 Twice or less from the initial specified value in total. Should not have any damages. |
| 5 冷熱衝撃試験 Thermal shock test | FPC/FFC を 5 回挿抜後嵌合した状態にて下図の温度条件を 1 サイクルとして 100 サイクル実施し、試験後接触抵抗測定及び外観観察を行う。 The connector and FPC/FFC mated are unmated at 5 times is exposed 100 cycles under the following temperature conditions. It shall be measured the contact resistance and observed its appearance after the test. | 50mΩ以下 外観異常なき事。 50mΩ or below. Should not have any damages. |

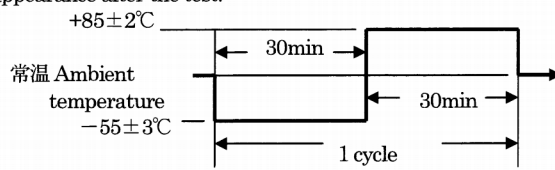

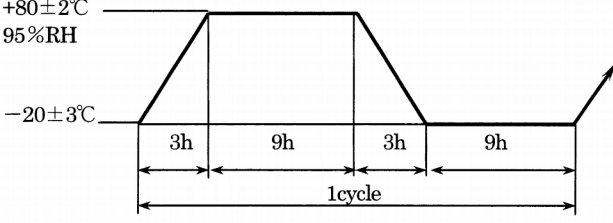
| 項目/Item | 条件/Test condition | 規格/Specification |
|--|--|--|
| 6 温湿度 サイクル試験 Humidity resistance | FPC/FFC を 5 回挿抜後嵌合した状態にて下図の温度条件を 1 サイクルとして 7 サイクル実施し、試験後接触抵抗測定及び外観観察を行う。 The connector and FPC/FFC mated are unmated at 5 times mated is exposed 7 cycles under the following temperature conditions. It shall be measured the contact resistance and observed its appearance after the test. +80±2℃ 95%RH  -20±3℃ 3h 9h 3h 9h 1cycle | 50mΩ以下 外観異常なき事。 50mΩ or below. Should not have any damages. |
| 7 H ₂ S ガス試験 H ₂ S gas test | FPC/FFC を 5 回挿抜後嵌合した状態にて、温度 40±2℃、相対湿度 75%、濃度 3±1ppm の雰囲気中に 96 時間放置し、試験後接触抵抗を測定する。 The connector and FPC/FFC mated are unmated at 5 times mated is exposed in the H ₂ S gas chamber 40±2℃, 75% RH 3±1ppm for 96 hours. It shall be measured the contact resistance after the test. | 50mΩ以下 外観異常なき事。 50mΩ or below. Should not have any damages |
| 8 SO ₂ ガス試験 SO ₂ gas test | FPC/FFC を 5 回挿抜後嵌合した状態にて、温度 40±2℃、相対湿度 75%、濃度 10±3ppm の雰囲気中に 96 時間放置し、試験後接触抵抗を測定する。 The connector and FPC/FFC mated are unmated at 5 times mated is exposed in the SO ₂ gas chamber 40±2℃, 75% RH 10±3ppm for 96 hours. It shall be measured the contact resistance after the test. | 50mΩ以下 外観異常なき事。 50mΩ or below. Should not have any damages |
| 9 塩水噴射試験 Salt spray test | FPC/FFC を 5 回挿抜後嵌合した状態にて、温度 35±2℃、濃度 5±1% の塩水噴霧中に 48 時間放置し、試験後接触抵抗を測定する。 The connector and FPC/FFC mated are unmated at 5 times mated is exposed in the salt spray chamber 35±2℃, 5±1% salt density for 48 hours. It shall be measured the contact resistance after the test. | 50mΩ以下 外観異常なき事。 50mΩ or below. Should not have any damages |

5-4. その他の性能

5-4. Other specification

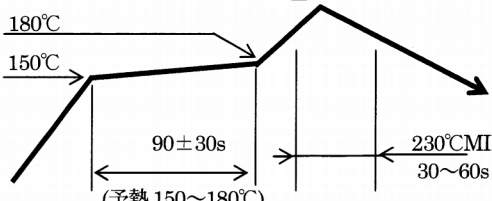
| 項目/Item | 条件/Test condition | 規格/Specification |
|---|---|--|
| 1 半田付け性 Solderability | コネクタの半田付け部をフラックスに浸漬した後、245±5℃の Sn-Ag-Cu 系の鉛フリー半田槽に 3±0.5 秒浸す。 The terminal of connector shall be put into the flux and dipped into Pb free solder bath (Type of Sn-Ag-Cu) 245±5℃, 3±0.5s. | 浸した面積の 95% 以上に半田が むらなく付着する事。 Solder shall cover 95% or more of the area that is dipped into the solder bath. |
| 2 半田耐熱性 Soldering heat test | 下記条件にて、半田耐熱性試験を行う。 The connector shall be tested resistance to soldering heat under the following conditions. 条件①：リフローの場合 (2 回) / In case of reflow (2 times) 250℃MAX. (ピーク温度)、10s MAX. (Peak temperature)  180℃ 150℃ 90±30s 230℃MIN. 30~60s (予熱 150~180℃) (pre-heat : from 150 to 180℃) 温度は製品上面の温度とする。 The temperature shall be measured on the surface of the Product. 条件②：手半田の場合 / In case of manual soldering. 半田温度 / Solder iron : 350±5℃ 時間 / time : 3±0.5s | 実使用上の問題無き事 Should not have any problems. |
| 3 温度上昇試験 Rise of temperature test | 最大許容電流を通電し、熱電対法にてコネクタの温度上昇を測定する。 The connector shall be operated in the maximum rise of current and measured rise of the temperature at contact point. | 温度上昇：30℃以下 Rise of temperature : 30℃ or below |

6. 製品の保管期限
製造日より1年とする。

6.Term of a guarantee
1 year from production date.

7.保存保管条件
室温で-10~+40℃の温度、75%以下の相対湿度で保管してください。

7.Storage conditions
Shall be stored in the house at -10~+40℃,75%RH or less .

8.故障率
MIL-HDBK-217D,2-11.2 プリント配線板コネクタに基づいて算出を行う。(単位：FIT)

8.Failure rate
Failure rate shall be calculated as MIL-HDBK-217D,2-11,2 (Unit : FIT)

| 極数/ckt | 故障率/Failure rate | 極数/ckt | 故障率/Failure rate | 極数/ckt | 故障率/Failure rate |
|--------|------------------|--------|------------------|--------|------------------|
| 4 | 2.04 | 17 | 4.23 | 30 | 6.65 |
| 5 | 2.22 | 18 | 4.41 | 31 | 6.85 |
| 6 | 2.40 | 19 | 4.58 | 32 | 7.05 |
| 7 | 2.57 | 20 | 4.76 | 33 | 7.26 |
| 8 | 2.73 | 21 | 4.93 | 34 | 7.47 |
| 9 | 2.90 | 22 | 5.12 | 35 | 7.69 |
| 10 | 3.06 | 23 | 5.30 | 36 | 7.91 |
| 11 | 3.23 | 24 | 5.48 | 37 | 8.13 |
| 12 | 3.39 | 25 | 5.67 | 38 | 8.35 |
| 13 | 3.56 | 26 | 5.86 | 39 | 8.58 |
| 14 | 3.72 | 27 | 6.05 | 40 | 8.80 |
| 15 | 3.89 | 28 | 6.25 | | |
| 16 | 4.06 | 29 | 6.45 | | |

9.ウイスキーに関して(錫系めっきの場合) 
本製品は、錫系のめっきを施しておりますので、ウイスキーが発生する可能性がございます。その為、ウイスキー発生に対する保証は困難であり、御社にて御判断の上御使用をお願いします。

9.About a whisker(In case of Sn plate) 
This product utilizes lead-free tin plating. Any product with lead-free tin plating is susceptible to tin whisker. Iriso provides no assurances against the growth of tin whisker even under normal operating conditions. Customers assume all responsibility for any product failures due solely to the growth of tin whiskers.

10. 和文と英文の差異について
和文と英文の内容に差異が生じた場合には、和文の内容を優先致します。

10. Difference between Japanese and English
When difference is found between Japanese Specifications and English Specifications, Priority shall be given to Japanese.

FPC/FFC 用コネクタ

Connector for FPC/FFC

I-Lock コネクタ
取り扱い説明書

I-Lock Connector Manual

適用製品：9665 シリーズ
Application product: 9665series

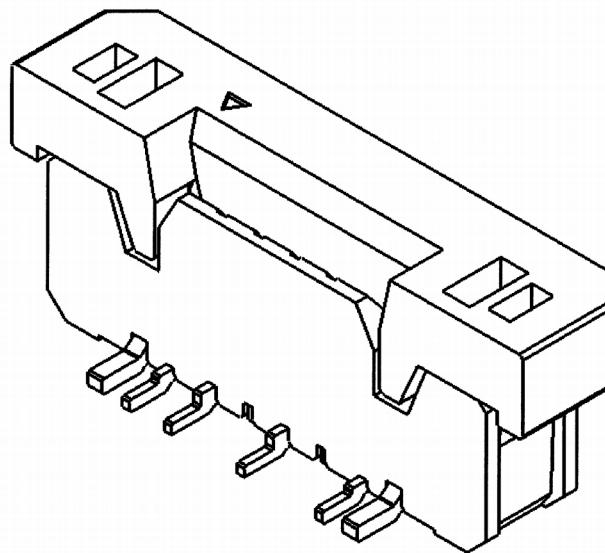

《コネクタの操作方法と注意点/Operation method and notes of connector》

・ 9665 シリーズ I - LOCK 1.0mm ピッチ I 型/9665 series I - LOCK 1.0mm pitch I type.

※ 図表記号の説明/Explanation for mark in below table

➡ 弊社推奨操作方法/Our recommendation operation method, ➡ NG 操作方法/ Method of operating NG

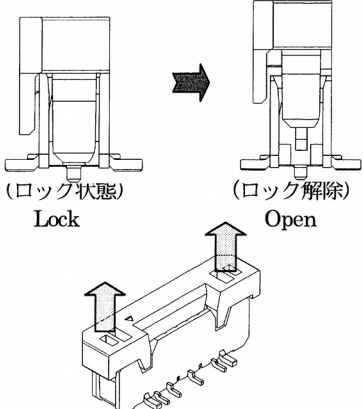
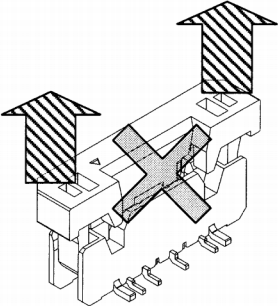
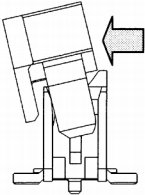
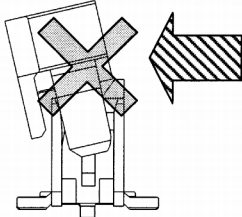
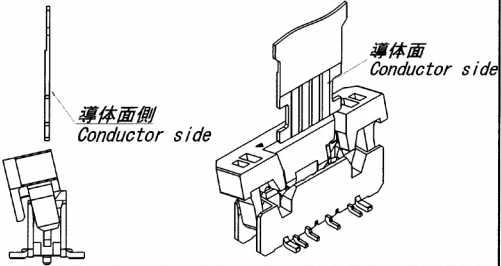
| 操作方法/Operation method | 使用上の注意点/Directions point |
|--|--|
| <p>1. FPC/FFC 挿入方法 Method of inserting FPC/FFC</p> <p>① スライダーの両端を引き出し、ロックを解除します。 Both ends of the slider are drawn out and the lock is released.</p>  | <ul style="list-style-type: none"> ・ スライダーは軽い力で引き出せます。無理な力をかけると破損の原因になります。 The slider can be drawn out by light load. Please note too much load. It causes damage.  |
| <p>② スライダーを図の様に傾けます。 これにより FPC/FFC を挿入し易くなります。 The slider is inclined only a little as shown in figure. As a result, FPC/FFC can be made easy to insert.</p>  | <ul style="list-style-type: none"> ・ 反対側には傾けないで下さい。 Please do not incline it to the other side. ・ 傾ける際には無理な力を掛けしないで下さい。 破損の原因となります。 When inclined slider, Please do not multiply too much load. It causes damage.  |
| <p>③ FPC/FFC を図の向きで挿入します。 奥まで確実に挿入して下さい。 FPC/FFC を挿入する際には FPC/FFC の補強板部分を持って挿入すると、確実な作業ができます。その為、FPC/FFC は補強板の長さが 15mm 以上のものを推奨致します。 Insert FPC/FFC like the direction of figure. Please insert it in the interior surely. Please insert the FPC/FFC holding the supporting tape. It makes insertion to easy. Therefore, FPC/FFC will recommend dimation of supporting tape is 15mm or more.</p>  | <ul style="list-style-type: none"> ・ FPC/FFC はコネクタに対してまっすぐ入れるようにして下さい。 ・ 補強板部分を持たないで挿入すると、カードが曲がり、作業性が悪くなる可能性があります。 ・ Please insert FPC/FFC straight into the connector. ・ There is a possibility that work efficiency worsens by the card bending if it tries to insert it without holding the supporting tape. |

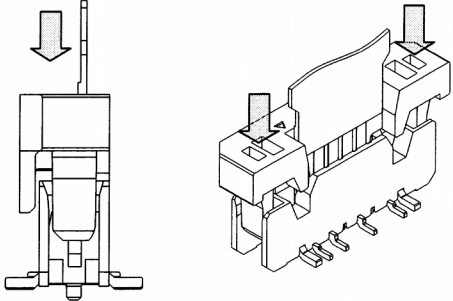
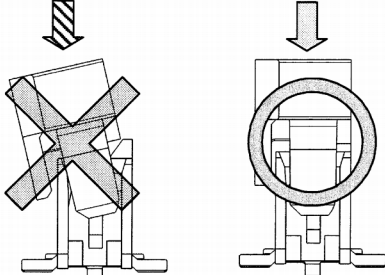
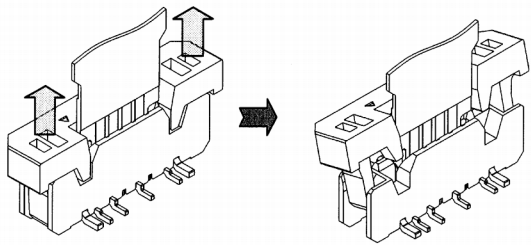
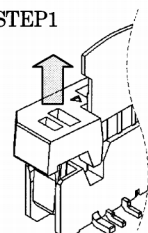
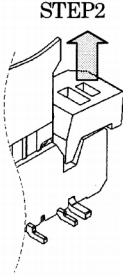
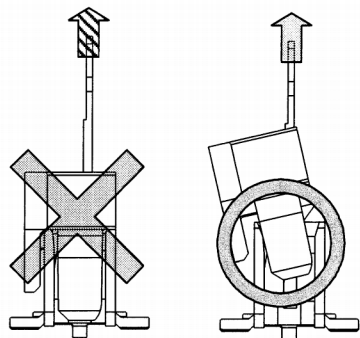
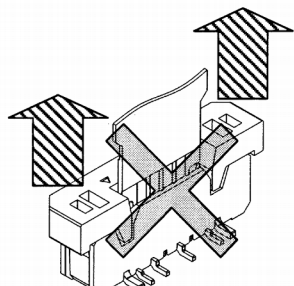
| 操作方法/Operation method | 使用上の注意点/Directions point |
|--|---|
| <p>④ スライダーを垂直に戻し、両端を押し込みます。 Returned slider to straight, and push both ends of slider the same time.</p>  | <ul style="list-style-type: none"> スライダーを傾けたまま押し込まないで下さい。必ずスライダーを垂直な状態に戻してから押し込んで下さい。破損の原因になります。 Please do not push it when the slider is inclining. Please push slider after it return to straight. It causes damage.  |
| <p>2. FPC/FFC 抜去方法 Method of pulling out FPC/FFC</p> <p>① スライダーの両端を引き出し、ロックを解除します。 Drawn out both ends of the slider. And release the lock.</p>  <p>※Note 多極数などでスライダーが引き出しにくい場合は、片側ずつ引き出す事により、操作が容易になる場合があります。 When the number of poles is large the slider is not drawn out easily. It becomes easy to operate if it at each side draws it out.</p> <p>STEP1</p>  <p>STEP2</p>  | <ul style="list-style-type: none"> スライダーをロックした状態で、FPC/FFC を引き抜かないで下さい。引き抜く際は必ずロックを解除した状態で行って下さい。 Please do not pull out FPC/FFC with the slider locked. Please pull it out with the lock released without fail. FPC/FFC を挿入した状態でスライダー引き出し時、過度の荷重をかけないで下さい。破損の原因になります。特に FPC/FFC 抜去時には十分ご注意下さい。 Please do not apply an excessive load when you draw out the slider with FPC/FFC inserted. It causes damage. Especially, be careful enough when FPC/FFC is pulled out.   |

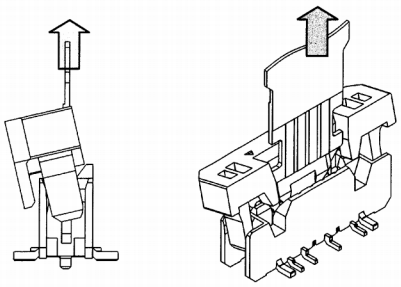
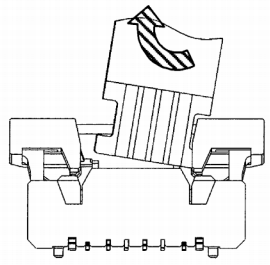
| 操作方法/Operation method | 使用上の注意点/Directions point |
|---|--|
| <p>② FPC/FFC を垂直に引き出します。 Pull out the FPC/FFC straight.</p>  | <ul style="list-style-type: none"> FPC/FFC を引き抜く際、斜めに傾けて引き抜きますと、下図のように FPC/FFC の切欠き部分がコネクタに引っかかる事があります。この様な状態で、FPC/FFC を無理に引き抜くと破損の原因になります。必ず、一度押し戻してから引き抜いて下さい。 <p>There is a thing caught to the cut out part of FPC/FFC at connector when FPC/FFC is pulled out with incline like the figure below. Under such a condition, when FPC/FFC is forcibly pulled out, it causes damage. Please pull it out after it pushes once and it returns it.</p>  |

・その他/Others

FPC/FFC の挿抜に関して、FPC/FFC の種類によっては、下記切かき部 (丸棒) の剥がれ等が発生する場合があります。剥がれ等が発生した場合、接触不良になる可能性がありますので、事前にご確認の上、使用する FFC/FPC の選定をお願い致します。また、挿抜回数を少なくすることにより剥がれの抑制が出来ます。

Please confirm A of FPC/FFC (see below) after durability.

Insulation occurs to fall off surface of FPC/FFC due to material of FPC/FFC by scratch. Then electrical contact open.

