

製品仕様書 / Product Specification	No.	I S - 9 6 8 6 T	来歴	/
	頁/Page	1 / 9		
標題 : 9686 シリーズ 0.5mmピッチ FPC/FFC コネクタ SUBJECT : Series 9686 0.5mm Pitch FPC/FFC Connector	制定年月日/ISSUED DATE 改訂年月日/REVISED DATE	2012-11-22 2013-5-15		

1. 適用範囲

本仕様書はイリソ電子工業株式会社製 9686 シリーズ 0.5mmピッチ FPC/FFC コネクタに関する仕様及び性能上の必要事項について規定する。

2. 構造及び寸法

構造、寸法、主要部品の材質、表面処理等は添付図による。
適合 FPC/FFC : 0.5mm ピッチ、厚さ : 0.3±0.05mm

△適用ソケット : IMSA-9686S-***-GFN1/GFN2/GFN4

3. 定格

- (1)最大定格電圧 : 50V (AC, DC)
- (2)最大定格電流 : 0.5A
- (3)使用温度範囲 : -40~+105℃

4. 試験環境

特に規定のある場合を除き、性能試験は、下記の試験条件のもとで行う。

- 常温 : 15~35℃
- 常湿 : 25~85%RH (相対湿度)

5. 性能

5-1. 電気的性能

1. Scope

This product specification is applied for IRISO ELECTRONICS CO.,LTD. Series 9686 0.5mm Pitch FPC/FFC Connector.

2. Configuration, dimensions and materials

See the product drawing attached.
FPC/FFC Mated : 0.5mm Pitch、t=0.3±0.05mm

△Applied to socket : IMSA-9686S-***-GFN1/GFN2/GFN4

3. Rating

- (1) Maximum rating voltage : 50 V(AC,DC)
- (2) Maximum rating current : 0.5A
- (3)Temperature range : -40~+105℃

4. Performances

All performance test, unless otherwise specified, is taken as per following environmental conditions.

- Ambient temperature : 15~35℃
- Ambient humidity : 25~85%RH

5. Performance

5-1.Electrical performance

項目/Item	条件/Test condition	規格/Specification
1 接触抵抗 Contact Resistance	短絡電流 1mA、最大開放電圧 20mV、周波数 1kHz のローレベル抵抗計にて測定する。 It shall be measured by the dry electric circuit specified as follows ; 1mA, 20mV, 1kHz frequency.	初期値 : 30mΩ以下 各試験後 : 50mΩ以下 Initial : 30mΩ or below. After each test : 50mΩ or below
2 耐電圧 Dielectric Withstanding Voltage	隣接する極間に AC250V を 1 分間印加する。 AC 250V shall be applied for one minute to between next terminals and the earth .	絶縁破壊等異常のない事。 Should not have any changes.
3 絶縁抵抗 Insulation resistance	隣接する極間に DC200V を印加する。 DC 200V shall be applied to between next terminals.	初期値 : 100MΩ以上 耐湿試験後 : 100MΩ以上 Initial : 100MΩ or more. After humidity test : 100MΩ or more
4 外観 Appearance	目視 Visual	有害となる割れ、剥がれ、ガタ、変形、変色のない事。 Should not have any flaw, scratch, discoloration, and crushed.

5-2. 機械的特性

5-2. Functional Performance

項目/Item	条件/Test condition	規格/Specification
1 端子の保持力 Contact retention force	端子に 25mm/分の速度で荷重を加え、端子がハウジングより抜け始めるまでの荷重を測定する。 It shall be pulled to the contact at the speed of 25mm per minute, and measured the force when the contact begins to remove from the housing.	0.98N 以上 0.98N or more
2 挿抜耐久性 Insertion /Extraction endurance	FPC/FFC を 20 回繰返し挿抜を行ない接触抵抗を測定する。 (カバーを開閉し、開時毎に挿抜する。) The FPC/FFC shall be mated and unmated 20 times and measured The contact resistance.	50mΩ以下 50mΩ or below.
3 振動試験 Vibration test	FPC/FFC を嵌合した状態にて、振動周波数 10~500~10Hz /掃引時間 12 分、振幅 1.5mm、又は加速度 98m/s ² のいずれか小さい方にて X Y Z 軸方向に各 2 時間計 6 時間の振動を加える。試験中、瞬断の有無の確認、試験後の接触抵抗の測定及び外観観察をする。 The connector and FPC/FFC mated is vibrated in the frequency range of 10~500~10Hz/12min and in the constant vibration amplitude 1.5mm or the acceleration of 98m/s ² . This motion is applied for period of 6 hours in one of 3 multilateral perpendicular directions (X,Y,Z-axis) included mating axis. It shall be tested the discontinuity of the contact current during the test and measured the contact resistance and observed its appearance after the test.	試験中 1 μs 以上の瞬断の無き事。 50mΩ以下 外観 : 異常なきこと Discontinuity : 1 μs or less. 50mΩ or below. Should not have any damages

項目/Item	条件/Test condition	規格/Specification
4 衝撃試験 Shock test	FPC/FFC を嵌合した状態にて治具に取り付け、加速度 980m/s ² 、衝撃作用時間 6ms を X,Y,Z,方向の 6 面に各 10 回加え、試験中の瞬断の有無の確認、試験後の接触抵抗の測定及び外観観察する。 The connector and FPC/FFC mated are installed in the machine. They are applied pulses 10 times to each 6 faces of 3 mutually perpendicular directions(X,Y,Z); in conditions as specified ; acceleration of 980m/s ² and shock pulses for a duration of 6ms . It shall be tested the discontinuity of the contact current during the test and measured the contact resistance and observed its appearance after the test	試験中 1 μs 以上の瞬断の無き事。 50mΩ以下 外観：異常なきこと Discontinuity : 1 μs or less. 50mΩ or below. Should not have any damages
5 微加振試験 Contact Pressure	微加振試験機にて、コネクタを試験基板に取り付け、全極直列に接続する。 The connector are set on a P.C.B and all of their terminals are wired in series then tested by test facility. 通電電流 current : 1mA 以下 1mA or below 衝撃値 shock : 980m/s ² 周波数 frequency : 1Hz 衝撃回数 cycling : 20000 回 20000 times 上記条件にて、試験中及び試験後の接触抵抗を測定する。 It shall be measured the contact resistance after the test.	総合接触抵抗が初期値の 2 倍以下 Twice or less from the initial specified value in total.
6 FPC/FFC 保持力 FPC/FFC retention force	FPC/FFC に 25mm/分の速度で加重を加え、ハウジングより抜け始めたときの荷重を測定する。 The FPC/FFC shall be pulled at the speed of 25mm per minute and measured the force when the FPC/FFC begins to remove from the housing.	0.29N/極 以上 0.29N/PIN or more.

5-3. 環境特性

5-3.Environmental performance

項目/Item	条件/Test condition	規格/Specification
1 高温保存試験 Heat resistance	FPC/FFC を 5 回挿抜後嵌合した状態にて温度 105±2℃の恒温槽に 1000 時間放置し、放置後接触抵抗測定及び外観観察を行う。 The connector and FPC/FFC mated are unmated at 5 times mated is exposed in the heat chamber 105±2℃ for 1000 hours. It shall be measured the contact resistance and observed its appearance after the test.	50mΩ以下 外観異常なき事。 50mΩ or below. Should not have any damages.
2 高温高湿保存試験 Humidity	FPC/FFC を 5 回挿抜後嵌合した状態にて温度 40±2℃、相対湿度 90~95%RH の恒温恒湿槽に 1000 時間放置し、放置後接触抵抗測定及び外観観察を行う。 The connector and FPC/FFC mated are unmated at 5 times mated is exposed in the heat chamber 40±2℃, 90~95%RH for 1000 hours. It shall be measured the contact resistance and observed its appearance after the test.	50mΩ以下 外観異常なき事。 50mΩ or below. Should not have any damages.
3 低温保存試験 Chilly resistance	FPC/FFC を 5 回挿抜後嵌合した状態にて温度 -40±3℃の低温槽に 1000 時間放置し、放置後接触抵抗測定及び外観観察を行う。 The connector and FPC/FFC mated are unmated at 5 times mated is exposed in the chilly chamber -40±3℃ for 1000 hours. It shall be measured the contact resistance and observed its appearance after the test.	50mΩ以下 外観異常なき事。 50mΩ or below. Should not have any damages.
4 低温負荷試験 Load of chill	FPC/FFC を 5 回挿抜後嵌合状態にて通電電流 1mA、-40±2℃の低温槽中に 96 時間放置する。 The connector and FPC/FFC mated are unmated at 5 times mated is exposed in the chilly chamber -40±2℃, 1mA for 96 hours. It shall be measured the contact resistance after the test.	総合接触抵抗が初期値の 2 倍以下 外観異常なき事。 Twice or less from the initial specified value in total. Should not have any damages.
5 冷熱衝撃試験 Thermal shock test	FPC/FFC を 5 回挿抜後嵌合した状態にて下図の温度条件を 1 サイクルとして 100 サイクル実施し、試験後接触抵抗測定及び外観観察を行う。 The connector and FPC/FFC mated are unmated at 5 times is exposed 100 cycles in the following temperature conditions. It shall be measured the contact resistance and observed its appearance after the test. +85±2℃ ← 30min → 常温 Ambient temperature ← 30min → -55±3℃ ← 1 cycle →	50mΩ以下 外観異常なき事。 50mΩ or below. Should not have any damages.

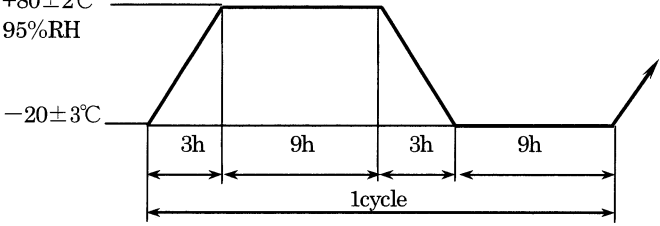
項目/Item	条件/Test condition	規格/Specification
6 温湿度 サイクル試験 Humidity resistance	FPC/FFC を 5 回挿抜後嵌合した状態にて下図の温度条件を 1 サイクルとして 7 サイクル実施し、試験後接触抵抗測定及び外觀観察を行う。 The connector and FPC/FFC mated are unmated at 5 times mated is exposed 7 cycles in the following temperature conditions. It shall be measured the contact resistance and observed its appearance after the test. +80±2°C 95%RH -20±3°C  1cycle	50mΩ以下 外觀異常なき事。 50mΩ or below. Should not have any damages.
7 H ₂ S ガス試験 H ₂ S gas test	FPC/FFC を嵌合した状態にて、温度 40±2°C 相対湿度 75%、濃度 3±1ppm の雰囲気中に 96 時間放置し、試験後接触抵抗を測定する。 The connector and FPC/FFC mated is exposed in the H ₂ S gas chamber 40±2°C, 75% RH 3±1ppm for 96 hours. It shall be measured the contact resistance after the test.	50mΩ以下 外觀異常なき事。 50mΩ or below. Should not have any damages
8 SO ₂ ガス試験 SO ₂ gas test	FPC/FFC を嵌合した状態にて、温度 40±2°C 相対湿度 75%、濃度 10±3ppm の雰囲気中に 96 時間放置し、試験後接触抵抗を測定する。 The connector and FPC/FFC mated is exposed in the SO ₂ gas chamber 40±2°C, 75% RH 10±3ppm for 96 hours. It shall be measured the contact resistance after the test.	50mΩ以下 外觀異常なき事。 50mΩ or below. Should not have any damages
9 塩水噴射試験 Salt spray test	FPC/FFC を嵌合した状態にて、温度 35±2°C、濃度 5±1% の塩水噴霧中に 48 時間放置し、試験後接触抵抗を測定する。 The connector and FPC/FFC mated is exposed in the salt spray chamber 35±2°C, 5±1% salt density for 48 hours. It shall be measured the contact resistance after the test.	50mΩ以下 外觀異常なき事。 50mΩ or below. Should not have any damages

5-4. その他の性能

5-4. Other specification

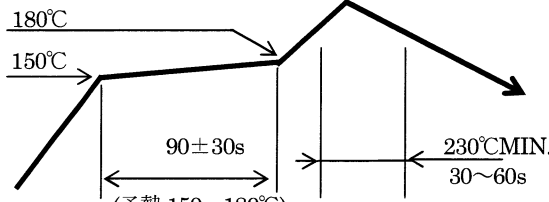
項目/Item	条件/Test condition	規格/Specification
1 半田付け性 Solderability	コネクタの半田付け部をフラックス浸漬した後、245±5°C の Sn-Ag-Cu 系の鉛フリー半田槽に 3±0.5 秒浸す。 The terminal of connector shall be put into the flux and dipped into Pb free solder bath (Type of Sn-Ag-Cu) 245±5°C, 3±0.5s.	浸した面積の 95% 以上に半田が むらなく付着する事。 Solder shall be covered 95% or more of the area that is dipped into the solder bath
2 半田耐熱性 Soldering heat test	下記条件にて、半田耐熱性試験を行う。 The connector shall be tested resistance to soldering heat in the following conditions. 条件①：リフローの場合 (2回) / In case of reflow (2 times) 250°C MAX. (ピーク温度)、10s MAX. (Peak temperature)  (pre-heat : from 150 to 180°C) 温度は製品上面の温度とする。 The temperature shall be measured on the surface of the Product. 条件②：手半田の場合 / In case of manual soldering. 半田鋺温度 / Solder iron : 350±5°C 時間 / time : 3±0.5s	実使用上の問題無き事 Should not have any problems.
3 温度上昇試験 Raise of temperature test	最大許容電流を通電し、熱電対法にてコネクタの温度上昇を測定する。 The connector shall be operated in the maximum raise of current and measured raise of the temperature at contact point.	温度上昇 : 30°C 以下 Raise of temperature : 30°C or below

6. 製品の保管期限
製造日より1年とする。

6. Term of a guarantee
1 year from product day.

7. 保存保管条件
室温で-10~+40℃の温度、75%以下の相対湿度で保管してください。

7. Storage conditions
Shall be stored in the house at -10~+40℃, 75%RH or less.

8. 故障率
MIL-HDBK-217D, 2-11, 2 プリント配線板コネクタに基づいて算出を行う。(単位: FIT)

8. Failure rate
Failure rate shall be calculated as MIL-HDBK-217D, 2-11, 2 (Unit: FIT)

極数/ckt	故障率/Failure rate	極数/ckt	故障率/Failure rate	極数/ckt	故障率/Failure rate	極数/ckt	故障率/Failure rate
4	1.76	16	3.51	28	5.40	40	7.60
5	1.92	17	3.66	29	5.57	41	7.80
6	2.07	18	3.80	30	5.74	42	8.01
7	2.22	19	3.96	31	5.91	43	8.21
8	2.36	20	4.11	32	6.09	44	8.42
9	2.50	21	4.26	33	6.27	45	8.64
10	2.64	22	4.42	34	6.45	46	8.85
11	2.79	23	4.58	35	6.64	47	9.07
12	2.93	24	4.74	36	6.83	48	9.29
13	3.07	25	4.90	37	7.02	49	9.51
14	3.22	26	5.06	38	7.21	50	9.74
15	3.36	27	5.23	39	7.41		

⚠ 9. 和文と英文の差異について
和文と英文の内容に差異が生じた場合には、和文の内容を優先致します。

⚠ 9. Difference between Japanese and English
When difference is found between Japanese specifications and English specifications, priority shall be given to Japanese.

FPC/FFC 用コネクタ

Connector for FPC/FFC

I-LOCK タイプ

取り扱い説明書

I-LOCK type

Manual

適用製品：9686 シリーズ

Application product: 9686series

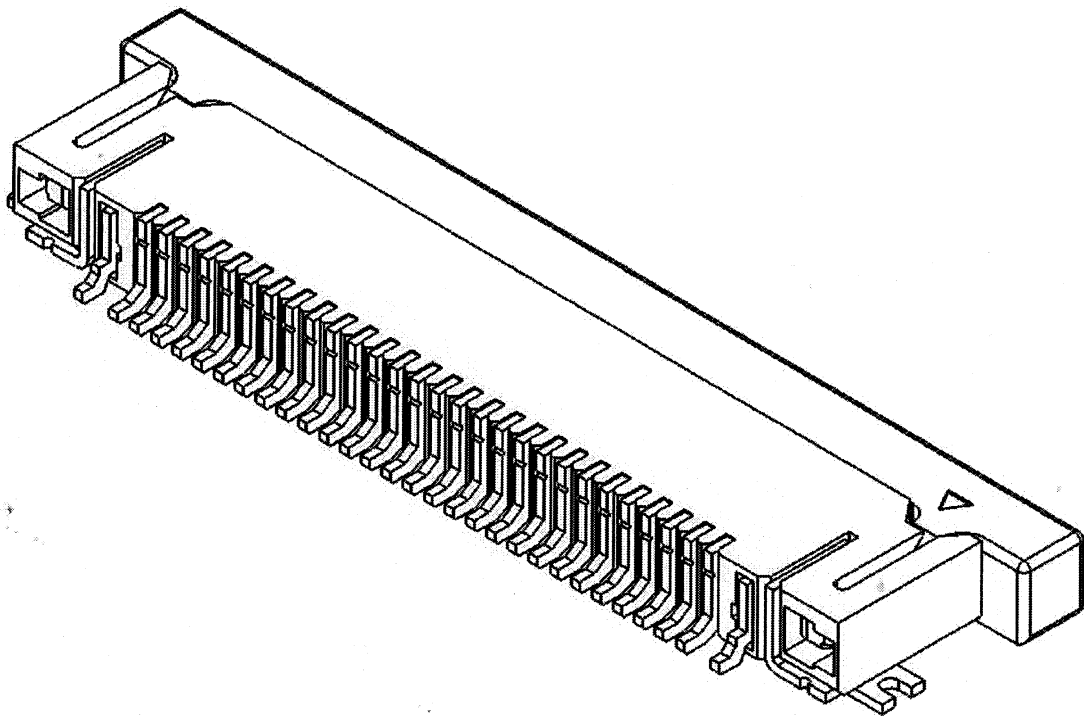



《コネクタの操作方法と注意点／Operation method and notes of connector》

- 9686 シリーズ I-LOCK 1.0mm ピッチ L型／9686 series I-LOCK 1.0mm pitch L type.

※量産前にご使用になる FPC/FFC との相性確認を行った上で、ご使用をお願い致します。
 ／Please check the compatibility between the connector and the FPC/FFC prior to mass production.

※図表記号の説明／Explanation for mark in below table

 弊社推奨操作方法／Our recommendation operation method,
  NG 操作方法／ Method of operating NG

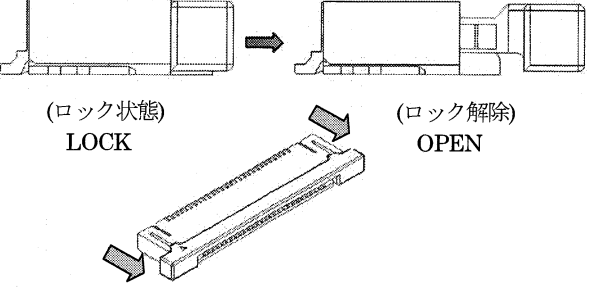
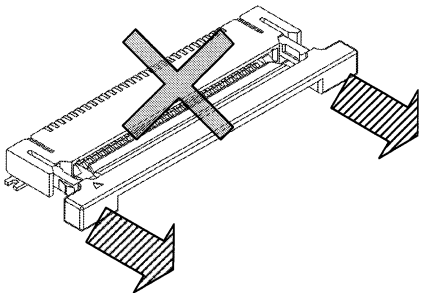
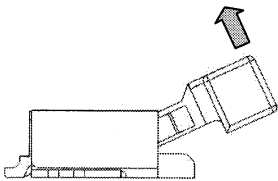
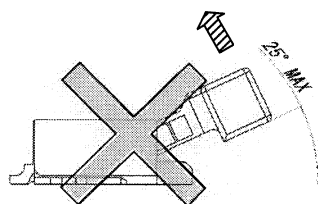
操作方法／Operation method	使用上の注意点／Directions point
<p>1. FPC/FFC 挿入方法 Method of inserting FPC/FFC</p> <p>①スライダの両端を同時に手前に引き出し、ロックを解除します Both ends of the slider are drawn out forward at the same time and the lock is released.</p>  <p>(ロック状態) LOCK (ロック解除) OPEN</p>	<ul style="list-style-type: none"> スライダは軽い力で引き出せます。無理な力をかけると破損の原因になります。 The slider can be drawn out by light load. Please note too much load. It causes damage. 
<p>②スライダを少しだけ上方向に引き上げます。これにより FPC/FFC を挿入し易くすることが出来ます。 The slider is improved only a little for above. As a result, FPC/FFC can be made easy to insert.</p> 	<ul style="list-style-type: none"> スライダを無理に上方向に引き上げないで下さい。破損の原因になります。 Please do not improve the slider forcibly for above. It causes damage. 

操作方法 / Operation method	使用上の注意点 / Directions point
-------------------------	----------------------------

③ FPC/FFCの導体面を下にして挿入します。奥まで確実に挿入して下さい。その際「カチッ」とした挿入感が得られると、奥まで挿入されたことが確認できます。

※FPC/FFCを挿入する際には、FPC/FFCの補強板箇所をしっかりと持って挿入して下さい。その為、FPC/FFCは補強板の長さが15mm以上のものを推奨致します。

The conductor side of FPC/FFC is done up and inserted. Please insert it in the interior surely. When the click feeling is obtained when inserting it, it can be confirmed to have been inserted in the interior.

Please insert the reinforcement board part of FPC/FFC firmly having it when you insert FPC/FFC. Therefore, FPC/FFC will recommend dimension of supporting tape is 15mm or more.

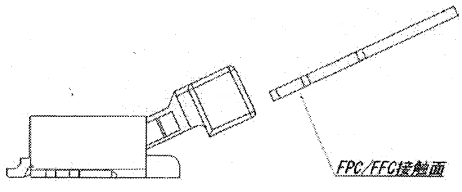

- ・ スライダーを押し上げたまま押し込まないで下さい。必ず押し下げてから押し込んで下さい。破損の原因になります。

Please do not push it with the slider pushed up. Please push it after it depresses it. It causes damage.

- ・ FPC/FFCの補強板箇所を持たないでFPC/FFCを挿入しようとする、カードが変形するなどして作業性が悪くなる可能性があります。



There is a possibility that work worsens by transforming the card if it tries to insert FPC/FFC without having the reinforcement board part of FPC/FFC.

④ スライダーを押し下げ、全面（網かけ部）を押し込みます。

The slider is depressed, push full (part of net) of slider the same time.

- ・ スライダーを傾けたまま押し込まないで下さい。必ずスライダーを水平な状態に戻してから押し込んで下さい。破損の原因になります。

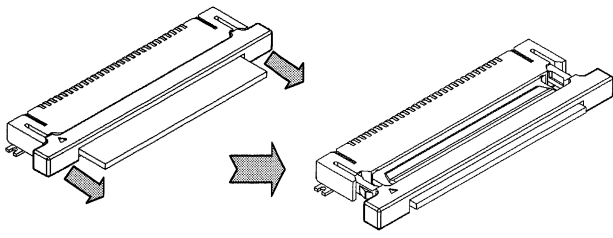
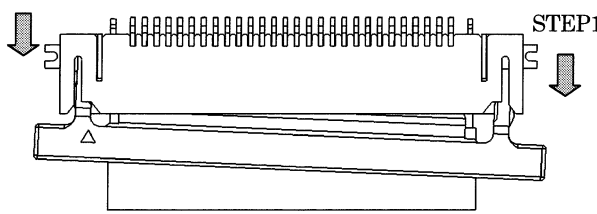
Please do not push it when the slider is inclining. Please push slider after it return to horizontally. It causes damage.

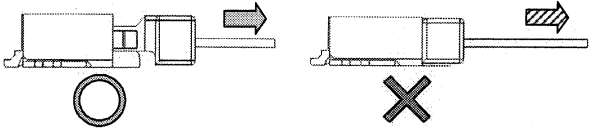
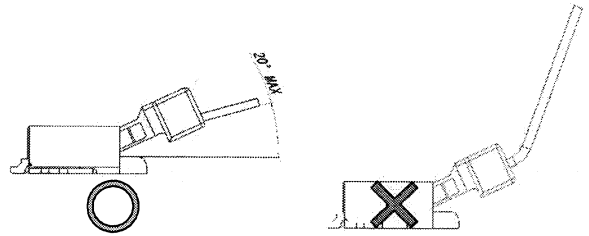
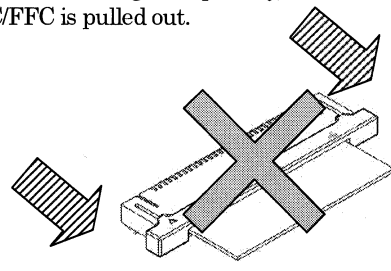
操作方法/Operation method	使用上の注意点/Directions point
<p>2. FPC/FFC 抜き方法 Method of pulling out FPC/FFC</p> <p>① スライダーの両端を同時に手前に引き出しロックを解除して、FPC/FFCを引き抜いて下さい。 Both ends of the slider are pulled out, and please release the drawing out lock forward at the same time, and pull out FPC/FFC.</p>  <p>※ Note 多極等などでスライダーが引き出しにくい場合などは片側ずつ引き出すと、より操作がし易くなる場合がございます。 The more operation might come to do easily if it one side draws it out when the slider is not drawn out easily by the fact that the number of poles is large etc. The slider is depressed, and both ends are pushed at the same time.</p> <p>STEP2</p>  <p>STEP1</p> 	<p>① ・スライダーをロックした状態で、FPC/FFCを引き抜かないで下さい。 引き抜く際は必ずロックを解除した状態で引き抜いて下さい。又、その時はカードを極度に上方向に傾けて引き抜かないで下さい。 Please do not pull out FPC/FFC with the slider locked. Please pull it out when you pull it out with the lock released without fail. Moreover, please do not pull it out extremely inclining the card for above at that time.</p>   <p>・ FPC/FFC を挿入した状態でスライダー引き出し時、過度の荷重をかけないで下さい。 破損の原因になります。特に FPC/FFC 抜き時には十分ご注意下さい。 Please do not apply an excessive load when you draw out the slider with FPC/FFC inserted. It causes damage. Especially, be careful enough when FPC/FFC is pulled out.</p> 

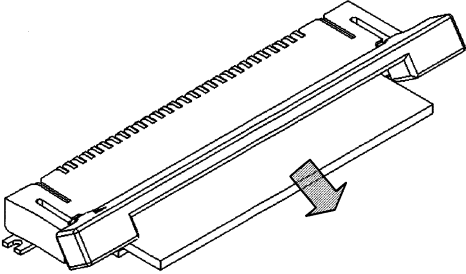
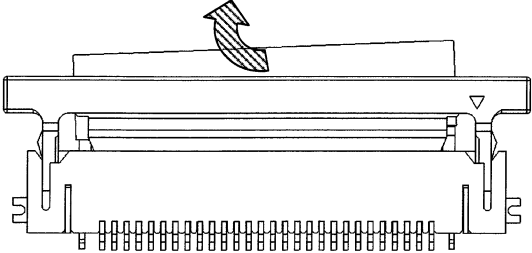
操作方法/Operation method	使用上の注意点/Directions point
<p>② FPC/FFC を真っ直ぐに引き出します。 Pull out the FPC/FFC straight.</p> 	<ul style="list-style-type: none"> FPC/FFC を引き抜く際、下図のような状態で斜めに傾けたまま無理に引き抜くと、破損の原因になります。必ず、一度押し戻してから引き抜いて下さい。 When FPC/FFC is pulled out, it causes damage when forcibly diagonally pulling it out while inclined as shown in the figure below. Please pull it out after it pushes once. 

・その他/Performance

FPC/FFC の挿抜に関して、FPC/FFC の種類によっては、下記切かき部 (丸棒) の剥がれ等が発生する場合があります。剥がれ等が発生した場合、接触不良になる可能性がありますので、事前にご確認の上、使用する FFC/FPC の選定を お願い致します。また、挿抜回数を少なくすることにより剥がれの抑制が出来ます。

Please confirm A of FPC/FFC (see below) after durability.

Insulation occurs to fall off surface of FPC/FFC due to material of FPC/FFC by scratch. Then electrical contact open.

